

**STRAIGHT BULKHEAD JACK FULL CRIMP-TYPE
PANEL SEAL CABLE 10/75 S**

R162.336.000

SERIES

N 75

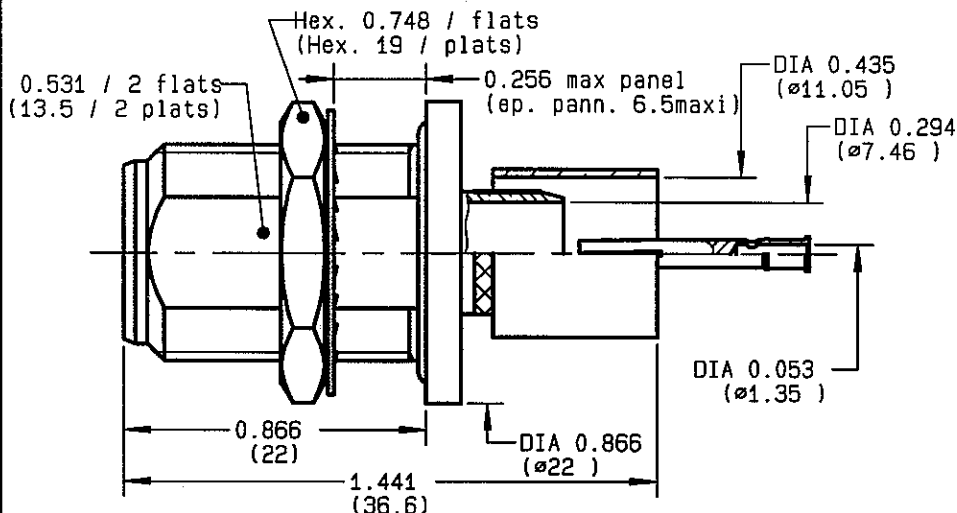

PERCAGE PANNEAU
MOUNTING HOLE

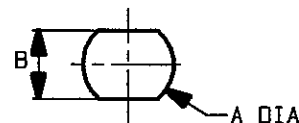

	MM		INCH	
	maxi	mini	maxi	mini
A	16.1	16	0.634	0.63
B	13.7	13.6	0.539	0.535

NOMINAL IMPEDANCE	75 Ω
FREQUENCY RANGE	0-1.5 GHz
TEMPERATURE RATING	-55/+155 °C
V.S.W.R	1.06 + x F(GHz)Maxi
RF INSERTION LOSS	0.15 √F(GHz) dB Maxi
VOLTAGE RATING	1400 Veff Maxi
DIELECTRIC WITHSTANDING VOLTAGE	2500 Veff Mini
INSULATION RESISTANCE	5000 MΩMini
HERMETIC SEAL	NA Atm.cm ³ /s
LEAKAGE (pressurized only)	NA
MECHANICAL DURABILITY	500 Cycles
WEIGHT	33.5 gr
SPECIFICATION	

CABLES : **KX 8**
RG 11
RG 144

OTHERS CHARACTERISTICS

CABLE RETENTION	300	N Mini
CENTER CONTACT RETENTION		
Axial force - mating end	27	N Mini
Axial force - opposite end	27	N Mini
Torque	NA	cm.N Mini
RECOMMENDED TORQUES		
Mating	NA	cm.N
Panel nut	500	cm.N
Clamp nut	NA	cm.N

CONNECTOR PARTS	MATERIALS	FINISH	(all values are given in micrometers)
BODY	BRASS	BBR 2	
OUTER CONTACT	BRASS	BBR 2	
CENTER CONTACT	BERYLLIUM COPPER	GOLD 0.5 OVER NICKEL 2	
INSULATOR	PTFE	-	
GASKET	SILICONE RUBBER	-	
OTHERS PIECES	BRASS	BBR 2	

GAUTIER

ISSUE	CREATION DATE	FILE PART-NUMBER
9733C00	28-OCT-94	



RADIALL®

The information given here is subject to change without notice. Design changes may be in order to improve the product.

Connect to the future



R162.336.000

ISSUE 9733C00 SERIES N 75

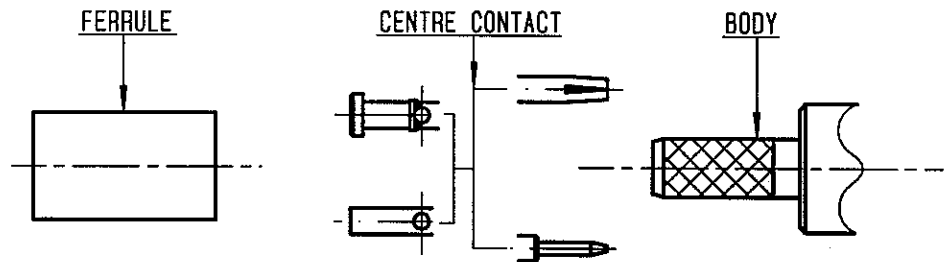

①

Slide onto the cable the ferrule
Strip the cable .

-
-

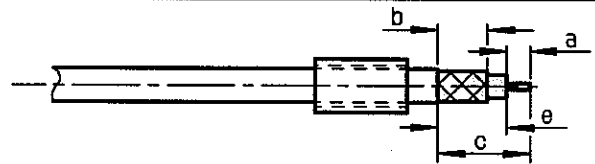

Stripping	a	b	c	d	e
inch	0.177	0.315	0.63	0	0.453
mm	4.5	8	16		11.5

②

Slide on centre contact until it bottoms against cable dielectrique .
Crimp centre contact .
Crimping tool : R282 223 000 (Hex. : 0.068)
or R282 293 000 (M22520/5-01)
+ dies R282 235 011 (M22520/5-11) .

-
-
-

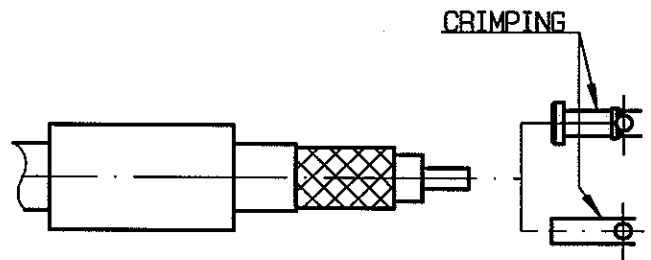

③

Fan the braid .
Slide cable into the body until bottoms against insulator .
Slide ferrule over the braid .
(In direction F)

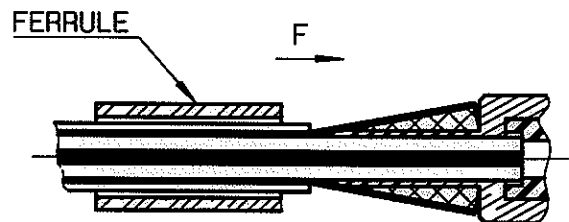

④

Crimp the ferrule with crimping tool
R 282 231 000 (Hex. : 0.415) or
crimping tool R282 293 000 (M22520/5-01)
+ dies R282 235 116 (Y 116 DANIELS)
Cut the excess of braid .

-
-
-
-

